

Harford Attachments

Tiltrotator

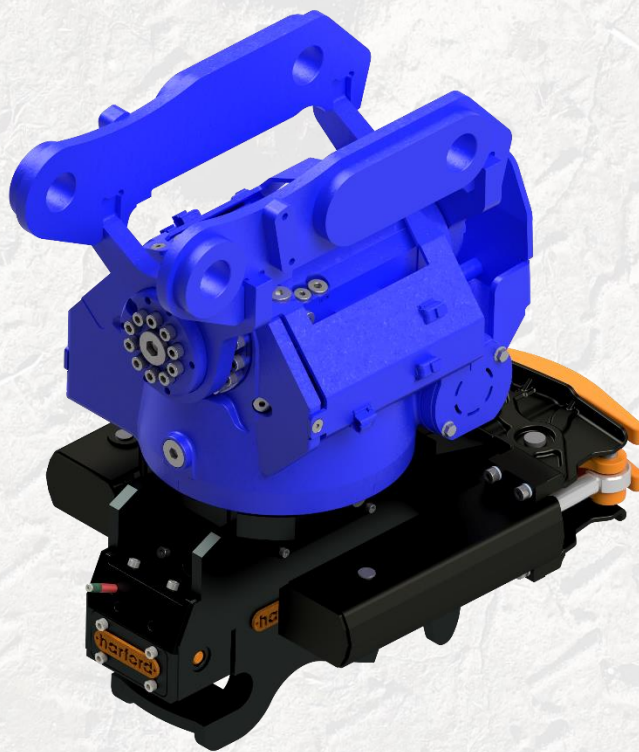

Product Information & Specification

CONTACT US

Call our Sales Teams now to discuss your requirements:
Europe: +44 (0) 1603 403099 | USA: + 1 (727) 222 6004

Introduction

The Harford Tiltrotator is our newest mini-excavator attachment innovation, offered in response to increased market demand for smart, multi-purpose excavating tools which dramatically improve machine productivity and return on investment. The Harford Tiltrotator increases operational efficiency and offers optimum excavator functionality. For operators who demand superior results and want to work quickly and precisely, even in restricted spaces, the Harford Tiltrotator is the performance product of choice.

Why Choose a Harford Tiltrotator?

- ✓ **Durability** – the robust, cast housing protects all the key operational components, even in the most challenging environments. The integrated Harford quick coupler is built to premium grade for superior performance every time.
- ✓ **Reliability** – The compact design means there are no protruding cylinders or pistons, which are prone to damage during excavator operations. All key components are securely contained in the robust cast housing, making the Harford Tiltrotator a very reliable partner.
- ✓ **Performance** – full, simultaneous 360° rotation and 50° tilt powers quick, easy tool changes and provides constant tilt torque throughout operations. This maximizes material handling capabilities, minimizes on-site movements and waste, thereby avoiding unnecessary excavation.
- ✓ **Ease of Use** – the range of operating systems and functionality are designed to suit the requirements of any operator, across all market sectors and applications. The quantity and quality of configurations and tools available ensures a more effective and tailored buying experience than with other brands of tilt-rotator.

CONTACT US

Call our Sales Teams now to discuss your requirements:
Europe: +44 (0) 1603 403099 | USA: + 1 (727) 222 6004

Key Features

360° Continuous Rotation & 50° Tilt

- ✓ With full, simultaneous 360° rotation and 50° tilt, the Harford Tiltrotator drastically reduces the need to reposition the excavator during operations. It therefore increases productivity, reduces downtime, and maximises operational capabilities, meaning you get the best performance from your equipment.

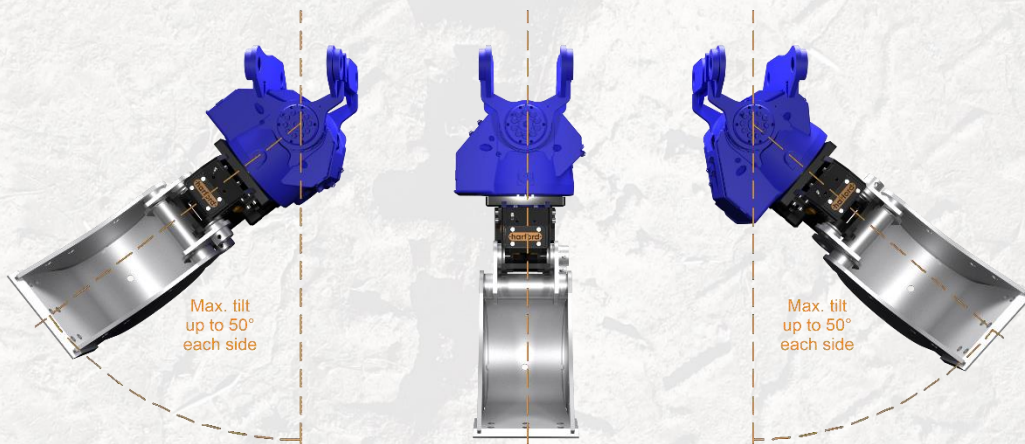

- ✓ The 50° tilt each side offers market leading performance and operational angle.
- ✓ Save time and money by utilizing the Harford Tiltrotator to increase operating speed and efficiency, enabling greater productivity in less time using less equipment.

Robust Cast Housing

- ✓ The robust cast housing of the Harford Tiltrotator ensures operators can work consistently in the most challenging conditions without the risk of causing critical damage to key components.
- ✓ Unlike many cast products, the Harford Tiltrotator housing is of a premium design and quality which ensures durability and provides peace of mind.
- ✓ In addition to being highly durable, the housing is also replaceable. So if years down the line your Harford Tiltrotator is in need of some aesthetic TLC, you can send it back for re-housing

CONTACT US

Call our Sales Teams now to discuss your requirements:
Europe: +44 (0) 1603 403099 | USA: + 1 (727) 222 6004

harford

excavator attachments

Key Features

Compact, Cylinderless Design

- ✓ The Harford Tiltrotator generates its tilt capability using elliptic piston technology, instead of the 2 external RAMS seen on other models.

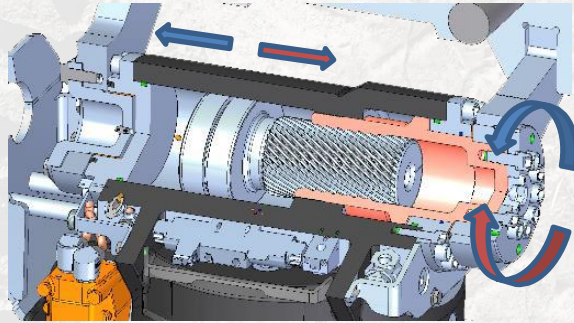

This design principle gives a strong and constant tilt torque, whereas competitors lose torque as the angle of tilt increases.

- ✓ Operators achieve more, using less space and do so without the risk of snagging and damaging expensive external RAMS.

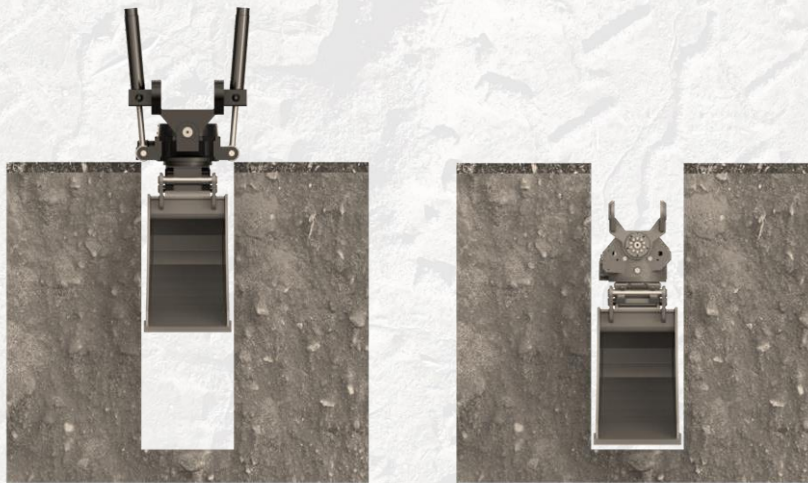

- ✓ This maximizes performance and ROI potential through increased efficiency, and reduced downtime due to reduced risk of damage to the Tiltrotator unit.
- ✓ Because of the compact, cylinderless design, operators can work right up to a fence line or adjacent wall with no compromise on accuracy - a unique advantage of the Harford Tiltrotator over other models.
- ✓ Operational visibility is improved by the slimline compact profile, with no protruding RAMS either side.

CONTACT US

Call our Sales Teams now to discuss your requirements:
Europe: +44 (0) 1603 403099 | USA: + 1 (727) 222 6004

Control Systems

The Harford Tiltrotator is a premium grade attachment with a huge range of capabilities, but we understand that not all operators will need or want the same format of controls or functionality. That's why we offer two different control systems, both of which have unique benefits. Whatever your application or operational environment, we can meet your specific needs and ensure you don't pay for features you don't need.

Here's an overview of the two control systems we offer for Harford Tiltrotators:

Prop +

- Advanced control system.
- Requires single acting hydraulic circuit (hammer line) on the excavator.
- New joysticks supplied and installed as part of this system to enable full functionality.
- Leica Geosystem compatible.
- Hi-definition touchscreen control panel.
- GPS ready.
- Autocalibration.
- CAN Bus system.
- Position Indicator.
- Up to 4 user profiles each with up to 10 tool profiles when swapping attachments.

DF4

- Entry level control system.
- Requires 2 double acting hydraulic circuits on the excavator.
- Compatible with standard machine joysticks, no replacement required.
- Single electrical connection into existing cab set up.
- Allows for simultaneous rotation and tilting.
- To operate the hydraulic coupler, one of the two hydraulic circuits is separated by a switch electronically connected to the existing joysticks.

	Prop +	DF4
GPS Ready	●	○
Autocalibration	●	
Angle Position Indication	●	
Individual Operator Settings	●	
Individual Speed Settings	●	
Touchscreen Control Panel	●	
Troubleshooting on Display	●	
Remote Maintenance	●	
Connectivity Tools (Bluetooth, LTE, WiFi)	●	
Fully Proportional Controls	●	○
Changing Roller Position	●	
Individual Tool Settings	●	
Tilt, Rotation & Extra Simultaneous Movement	●	
Quick Coupler Control	●	
	Standard	●
	Optional	○

CONTACT US

Call our Sales Teams now to discuss your requirements:
Europe: +44 (0) 1603 403099 | USA: + 1 (727) 222 6004

Attachments

Integrated Gripper

- ✓ Integrated RG Gripper option provides an additional attachment for handling poles, tubes, sleepers, stones and much more. With a weight capacity of 300kg, opening to a width of 16.5" in 1.5 seconds, it's sure to be a new favourite for operators when partnered with our Tiltrotator.

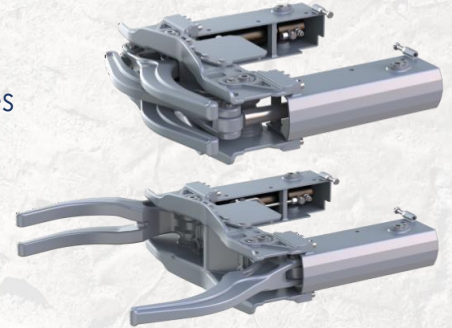

Scandinavian Profile Buckets

- ✓ Reinforced side plates for strength and durability plus a sleek side profile make these buckets move more swiftly through the ground and release material quicker than a conventional bucket. Our Scandinavian profile buckets are the perfect addition to our Tiltrotator and available for digging, grading and trenching or cable applications.
- ✓ Combine the Harford Tiltrotator with Scandinavian profile buckets, for perfect landscaping results.

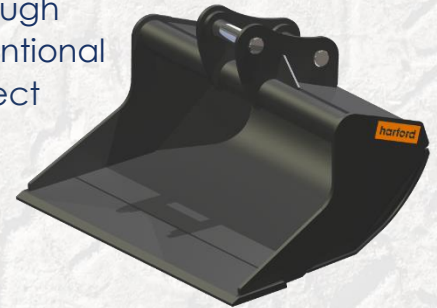

Fork Tines

- ✓ Lifting, moving and positioning of palletized or unpalletized materials becomes straight forward with this fork tine attachment, featuring a high lifting capacity and lightweight design, it's a very efficient tool with high ROI potential.

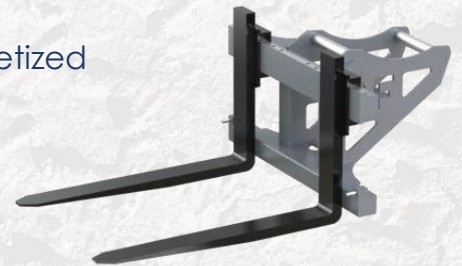

Other Attachments

- ✓ We offer a comprehensive range of attachments, both standard and specialized, all made from the highest quality materials. With over 30 years' experience of manufacturing premium excavator attachments, we provide quality products that you can consistently rely on to get the job done.

CONTACT US

Call our Sales Teams now to discuss your requirements:
Europe: +44 (0) 1603 403099 | USA: + 1 (727) 222 6004

Installation

As with all our hydraulic products, we offer a full installation process for the Tiltrotator. We allow 2 days for the installation process regardless of the machine type or control system, to ensure we provide our customers with the most comprehensive service possible. Price guide available on request.

Warranty and Aftersales Support

Every Harford Tiltrotator produced comes with a 2-year comprehensive warranty. With the robust warranty response procedures, you can rest assured that we will be ready to assist you whenever required.

As a company we pride ourselves in offering products with integrity and the highest standard of customer service before and after sale. We have built our business over the last 30 years with long-term partnerships in mind, which is why we continue to dedicate ourselves to aftersales support as strongly as initial product development.

The Next Steps

Please get in touch with our dedicated sales and customer service team at:

sales@harfordattachments.com

01603 403099 (UK and Europe) OR (727) 222 6004 (USA)

We'll work with you to answer any questions you have about this and any associated products, to ensure you can make an informed decision about which configuration works best for you.

CONTACT US

Call our Sales Teams now to discuss your requirements:
Europe: +44 (0) 1603 403099 | USA: + 1 (727) 222 6004